

Economic and Structural Advantages of Precast/Prestressed Concrete Building

^{1*} Monalisha Mallick, ² Pritam Jena

^{1*} Asst. Professor, Dept. Of Civil Engineering, NIT BBSR,

² Asst. Professor, Dept. of Civil Engineering, BCE, BLS

^{1*} monalishamallick@thenalanda.com, jena.pritam@gmail.com

The benefits of using precast/prestressed concrete in structural frames are discussed in this article. utilising cast-in-place composite materials along with pretensioned concrete components concrete topping creates a lighter

structural system than a structure that is entirely cast in place. Even more member size reduction is possible by shoring pretensioned beams and slabs before covering them with composite material. Functional joinery systems can be utilised instead of, or in addition to, a variety of other connection methods, such as mechanical couplers, by extending the reinforcing steel from the precast components. Precast modules can be incorporated into a comprehensive system to create a building frame that performs monolithically and has the strength, stiffness, and longevity to withstand seismic loadings.

The author, a PCI Medal of Honor Award winner, has, during the last 40 years, designed and constructed hundreds of precast/prestressed concrete structures along the Pacific Rim which have successfully withstood severe earthquakes.

▲ Precast/prestressed concrete has long been praised by architects and engineers for its high-quality architectural and structural products. Precast concrete products can be made in a wide range of sizes and shapes, and the use of prestressing enables far longer spans than are possible with traditional in situ construction techniques. Complex geometric configurations requiring difficult forming procedures, especially for architectural concrete, can be fabricated and installed more economically by precasting than by forming and casting the concrete in place.

Precast concrete products are manufactured in carefully regulated industrial environments. In order to create their products with precise dimensional accuracy and uniformity in finishes and textures, precast product manufacturers can.

Figs. 1 through 4 display a few instances of successful pre-cast concrete applications. Refer to References 1, 2, and 3 for background information on precast technology and its applications.

COMPOSITE BEAMS AND SLABS

Several examples will serve to illustrate the substantial savings in structural concrete and steel quantities that precast/prestressed concrete can provide. A pretensioned precast slab can be combined compositely with an in situ concrete topping to produce a slab that provides substantial savings in materials over an equivalent conventional cast-in-place slab. Fig. 5(a) illustrates this advantage, based on shoring the precast slab at midspan before placing the cast-in-place concrete topping. In addition to the savings in material quantities, savings in formwork are also realized because the precast slab serves as formwork and simultaneously becomes a large portion of the composite slab structure.

For structural beam elements, definitive cross-sectional patterns that maximize strength and minimize material quantity result in structural efficiency and economy. For a simple rectangular beam, a pretensioned precast concrete beam with a composite cast-in-place slab can provide substantial savings in concrete and reinforcing steel. Designing a more structurally efficient geometric cross section for the pretensioned beam will reduce the material quantity even more and provide further savings [see Fig. 5(b)].

Initial formwork costs for this more efficient cross section may be higher than that for a rectangular section, but by using the formwork repetitively on a mass production scale, the formwork cost per unit produced would be insignificant when compared with the accumulated savings in material quantity in the precast elements. This benefit is important not only for its immediate economical savings, but also for its long-term environmental benefits of conserving energy, saving natural resources, and preserving the world's ecosystem.⁴

BENEFITS OF SHORING

For many years, the issue of shoring or non-shoring of the precast elements before placing concrete in situ has been a matter of debate. In areas with high labor costs, such as in North America, contractors tend to avoid shoring in order to speed up construction. This, however, would require larger, heavier precast units that contain more concrete, prestressing strand, and reinforcing steel to support the subsequent



Fig. 1(a). Precast, prestressed trellis beam being erected on the Kahala Mandarin Oriental Hotel in Honolulu, Hawaii.



Fig. 1(b). View of the completed latticework and balconies.



Fig. 2(a). Lifting roof parapets into place on the Queen Emma Gardens building in Honolulu.



Fig. 2(b). The completed structure with precast façade walls, sunshades, and roof parapets.



Fig. 3. The 33-story Ala Moana Apartments, Honolulu, built in 1966. Precast components include precast floor slabs with an in situ composite topping, balcony slabs, and wall panels.



Fig. 4. Headquarters Building, Saudi Arabia Monetary Agency, Riyadh, Saudi Arabia. Precast components include floor beams and slabs, columns, and bearing wall panels.

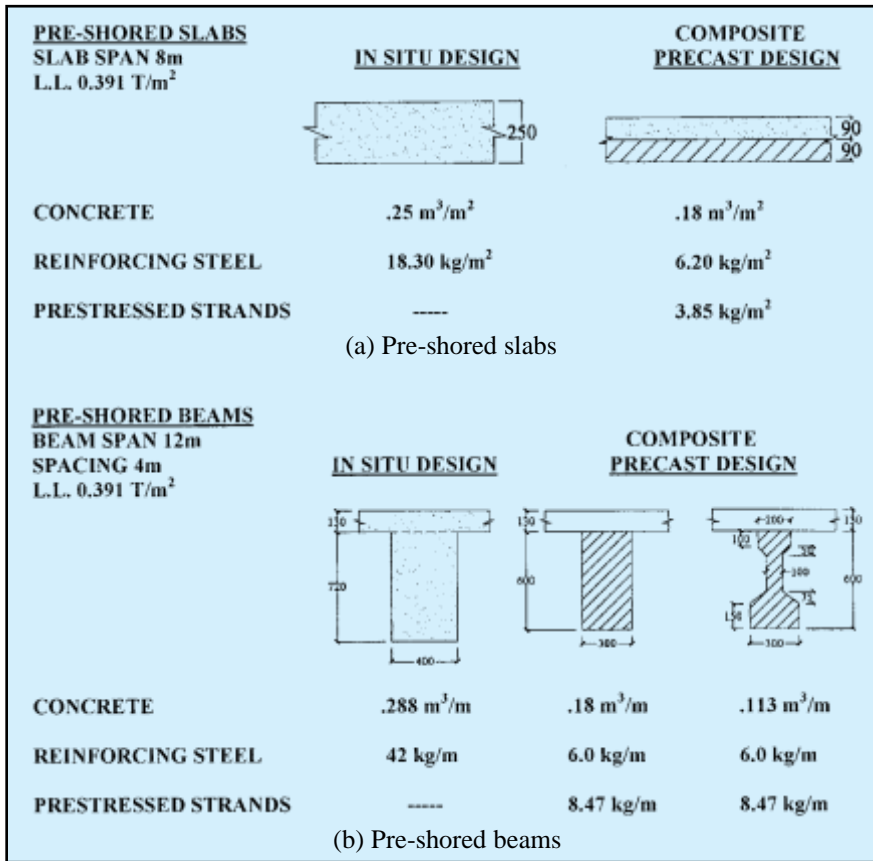
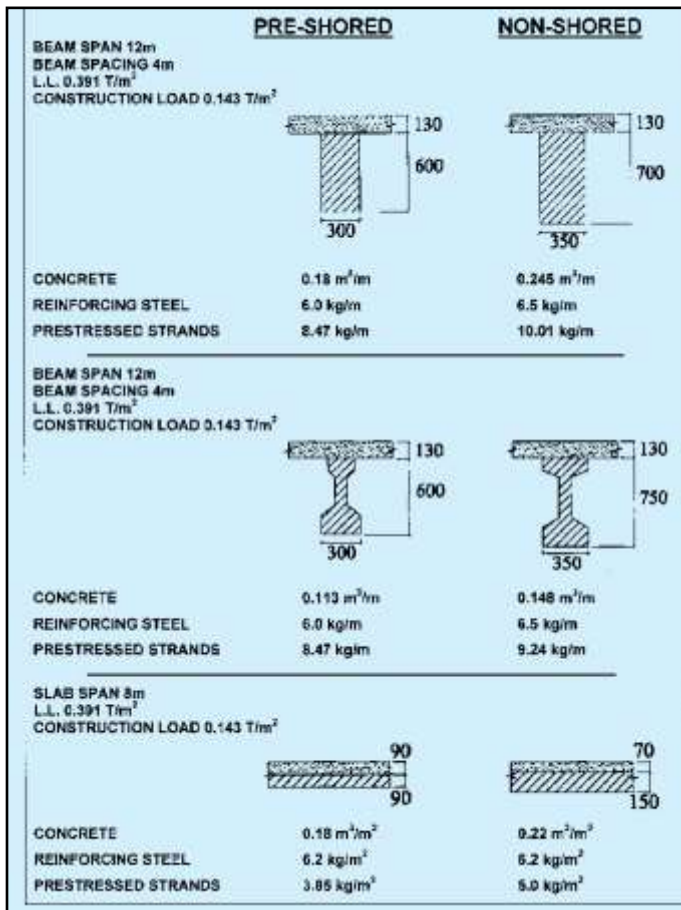

Fig. 5. Materials savings using precast/prestressed concrete.

Fig. 6. Materials savings by shoring the precast members to receive the composite topping.



loading of the plastic cast-in-place concrete before composite action takes place. In addition to the negative environmental effects of greater material consumption, heavier precast units are more expensive to handle, transport, and erect. They also require larger and more expensive foundations and columns to support them.

Shoring the precast beam or slab reduces temporary bending moments in the element due to the wet weight of the cast-in-place slab, thus resulting in a substantial reduction in the quantity of concrete and steel required in the precast element. The question is, are the cost savings in material greater than the cost of shoring? A comparison of shored and non-shored construction is provided in Fig. 6. Note that the savings in concrete and steel quantities can be substantial when the precast elements are shored, but one must compare these savings with the cost of shoring.

Consider some of the other benefits of shoring. For example, shoring each member at midspan of each precast beam or slab can produce a uniform camber from member to member. Because the shoring supports the precast units and therefore limits deflection and joint rotation during placement of the composite decking, the negative moment reinforcing steel is more effective in resisting superimposed dead and live load moments. Furthermore, initial cambering can be induced by shoring to desired levels to offset anticipated long-term deflections.

For bridge structures, shoring may be impractical because of the great heights required for shoring, the difficulty in shoring over water hazards, or the undesirability to interrupt traffic below the structure. In these cases, the precast concrete elements are typically designed to support the in situ composite concrete without shoring.

SHEAR RESISTANCE

Precast slabs and beams are generally combined compositely with in situ concrete in order to develop the required bending moment and shear resistance. In beams with typical spans and loading conditions, the steel area in the vertical web ties extending into the in situ slab is designed to resist vertical beam shear. This area of steel is also usually adequate to develop the required horizontal shear stress between the precast beam and the in situ

slab. For heavily loaded members, such as those that support machinery or landscaping, horizontal shear stress between the precast beam or slab and the in situ concrete may be excessively high and require special attention.

Various building codes provide design guidance for these horizontal shear tie requirements. The ACI Building Code (ACI 318-99)⁵ states that, when ties are provided, they shall not be less than that required for the vertical shear design of the beam element. In the case of composite slabs of precast and in situ concrete, shear reinforcement ties between the precast slab and the in situ topping may be omitted for ordinary building occupancy loads and spans if the top surface of the precast slab is made rough by brooming before the concrete topping is placed.

Research and testing at Purdue University⁶ have firmly established that the nominal ultimate horizontal shear stress for this broom finish contact surface without shear ties is 793 kPa (115 psi). These tests are based on both equivalent static loading and cyclic loading to 1 million cycles.

Fig. 7 illustrates the test setup and loading patterns at Purdue University. Fig. 8 gives calculated horizontal shear stresses for a composite slab under ordinary building spans and loadings. Note that for spans of 4 and 8 m (13 and 26 ft), the factored horizontal shear stresses are 258 and 423 kPa (37 and 61 psi), respectively, for a 0.391 t/m² (80 psf) live load condition.

These horizontal shear stresses are substantially lower than the 793 kPa (115 psi) limitation for full composite action without shear ties. Therefore, it is generally accepted that, for ordinary building loads and spans [4 to 8 m (13 to 26 ft)], no shear ties are required for precast slabs that are broom finished before the application of a composite concrete.

CONNECTION METHODOLOGY

The most versatile and practical method of connecting precast elements together to form a structural frame is to extend the reinforcing steel from the precast units into the in situ reinforced concrete. This method reduces the sensitivity to precast concrete dimensional tolerances and pro-

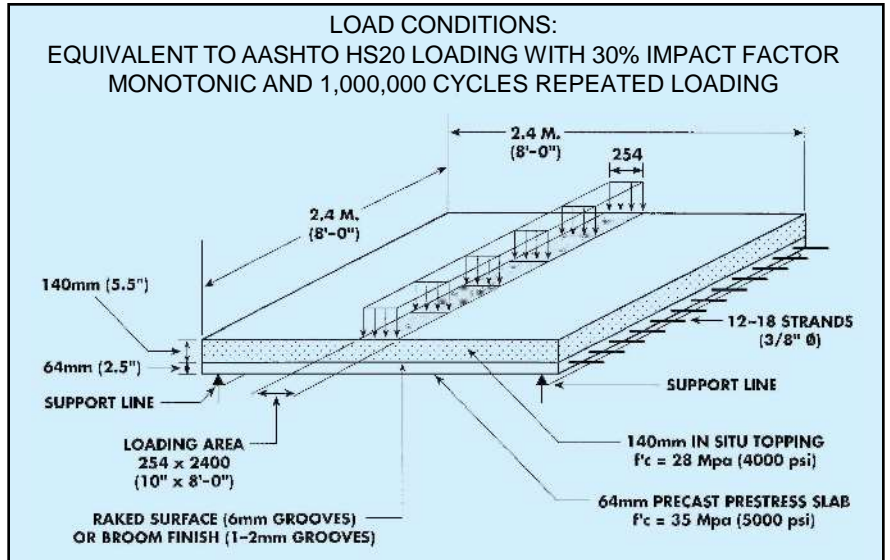

Fig. 7. Horizontal shear tests at Purdue University, showing the test setup and loading patterns.⁶

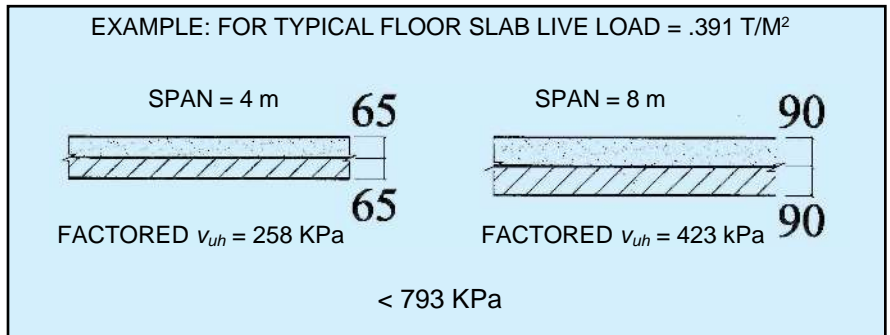

Fig. 8. Calculated horizontal shear stresses for a composite slab under ordinary loading conditions.

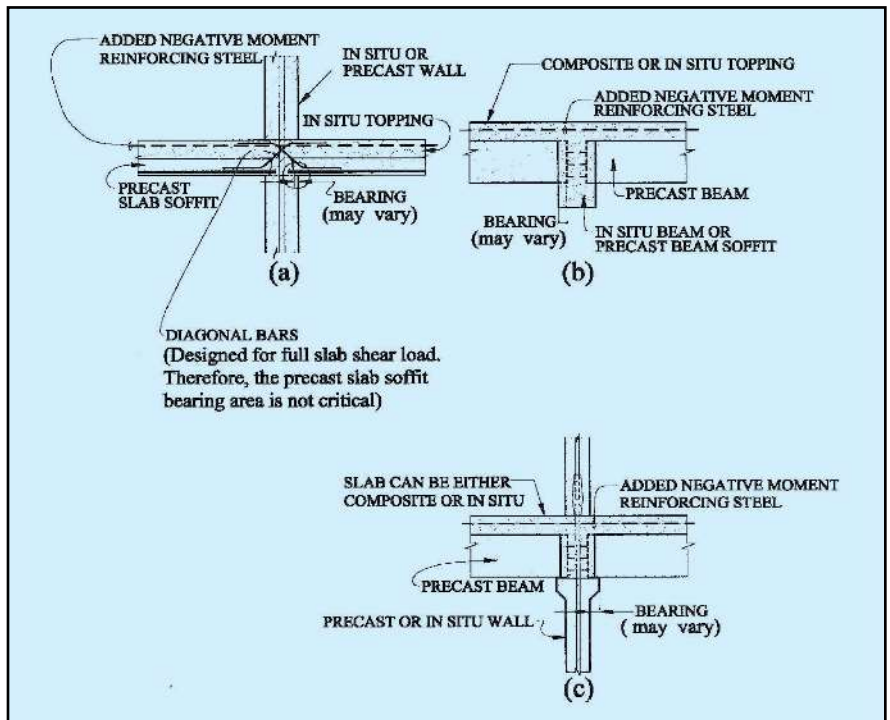

Fig. 9. Examples of typical composite concrete connections.



Fig. 10. Reinforcing steel for developing continuity and composite action.
 (top left) Note that an error in the precasting length resulted in the slab soffit not bearing directly on the precast wall as originally intended.
 (top right) However, when extended diagonal reinforcing steel is finally bent over the wall support, the composite slab will realize its full intended vertical shear strength without the need for bearing directly on the precast wall.
 (right) Cross section through wall.

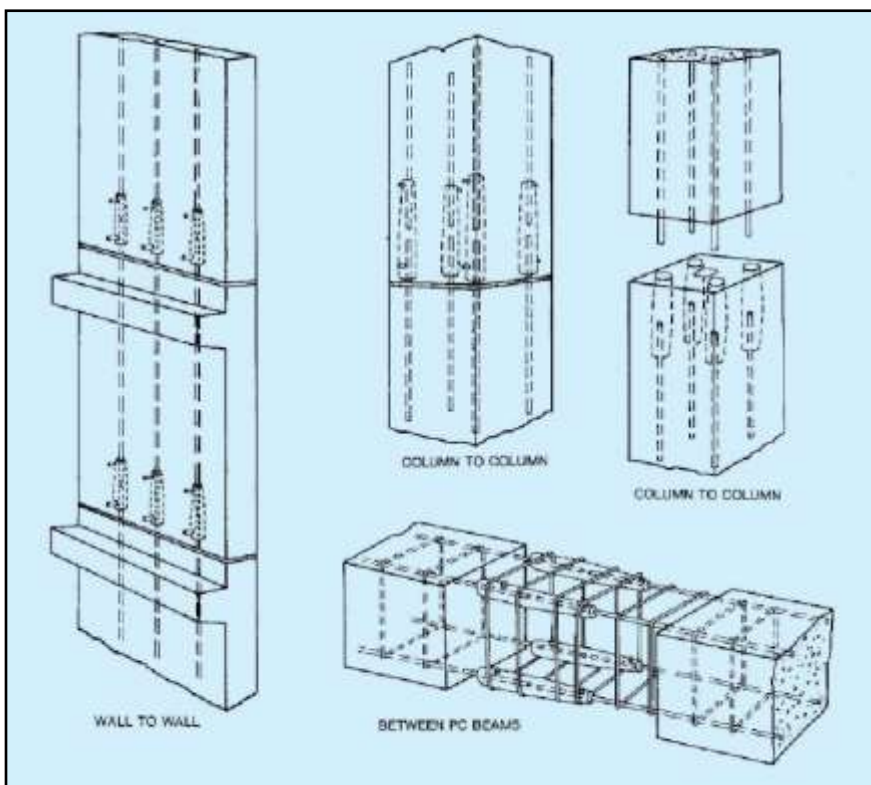
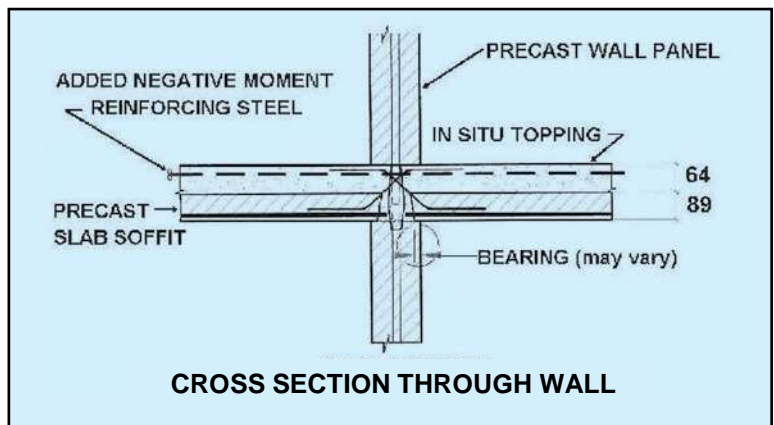

Fig. 11. Typical arrangements of splice sleeve connections in different precast concrete components.

vides structural safety, continuity, and monolithic action at all connections throughout the framing system. It also alleviates the close precision normally required in member dimensions and in erection operations while providing virtually “fail-safe” connections.

Some examples of composite connections are illustrated in Fig. 9. Note that with the type of in situ connections shown, small variations from specified bearing lengths do not affect the structural integrity. The in situ concrete can absorb these dimensional differences quite easily and furnish the medium for added reinforcing steel needed to develop full continuity and composite action in the system.

The added negative moment reinforcing steel not only develops continuity, but it also acts as a mechanism for developing high compressive forces at the end face of the bearing edge of the precast beam or slab. This aids in developing shear friction, which increases the resistance of this joint to vertical shear, and reduces the importance of the bearing area required between the precast beam or

slab and the supporting girder or wall. Reinforcing steel or prestressing strand from the precast beam or slab can also extend beyond the end faces of these elements to generate additional shear friction resistance.

In seismic areas where moment reversal is anticipated in these joints, the extension of the bottom steel from the precast beam or slab can be welded or clamped together to develop the required positive moment.

Note in Fig. 9(a) that, for precast slabs supported by bearing walls, there is generally very little bearing area because the bearing walls are relatively thin. In this case, diagonal bars extending out from the bearing edge of the precast slab cross over the bearing wall and anchor into the in situ topping. These diagonal bars are designed to develop the full vertical shear requirements of the composite slab.

This mechanism provides a joint that is safe enough so that, even if the precast slab does not bear on any part of the wall, the connection would still be structurally adequate because the entire vertical shear load in the composite slab can be supported by the extended diagonal bars. With the added negative moment steel in the composite topping, the mechanism developing high compressive forces at the end face of the precast slab is mobilized to provide additional shear friction resistance.

This concept is illustrated in Fig. 10, where a slab was not long enough to bear on the precast bearing walls as originally designed. This was not a significant problem, however, because the diagonal bars extending from the precast slab provided a structurally adequate connection without any modifications.

Mechanical steel couplers for connecting reinforcing steel bars in precast concrete have been widely used to join vertical structural elements such as columns and wall panels. They have also been used effectively to connect horizontal precast units together (see Fig. 11).

For precast columns, couplers can be embedded into the precast units and grouted by injection from the exterior, resulting in a fully continuous reinforcing steel splice with no pockets to patch during erection. These couplers have been tested in full-scale prototype precast concrete frame action as well as under 5-million-cycle repetitive loading (see Fig. 12).^{7,8}

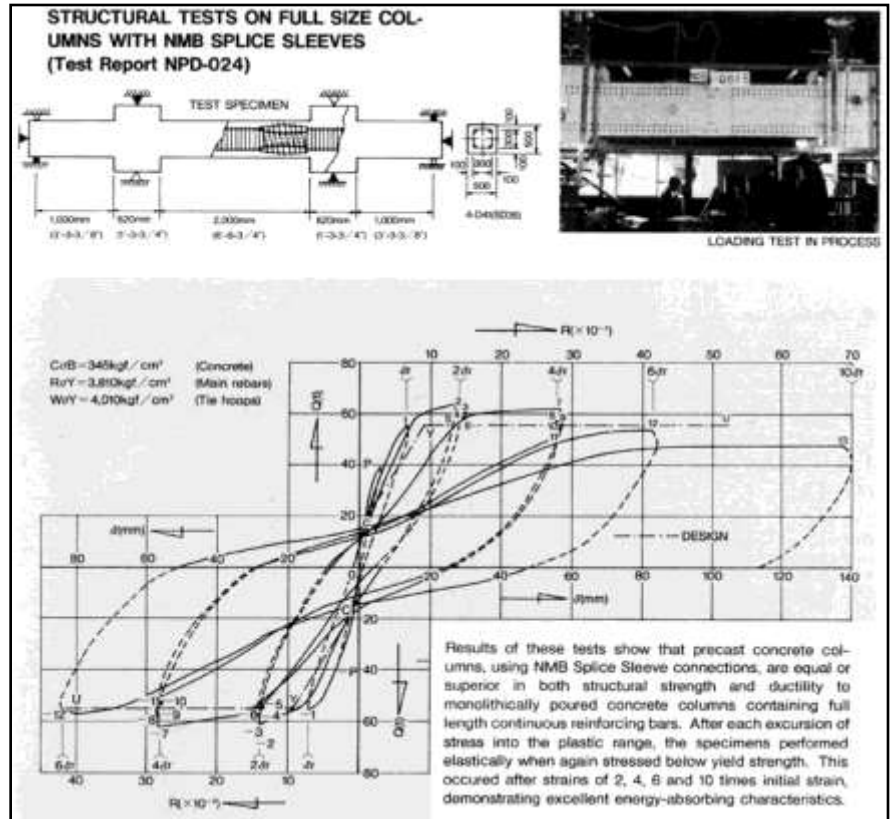

Fig. 12. Testing reinforcing splices on full-size columns with NMB splice sleeves.

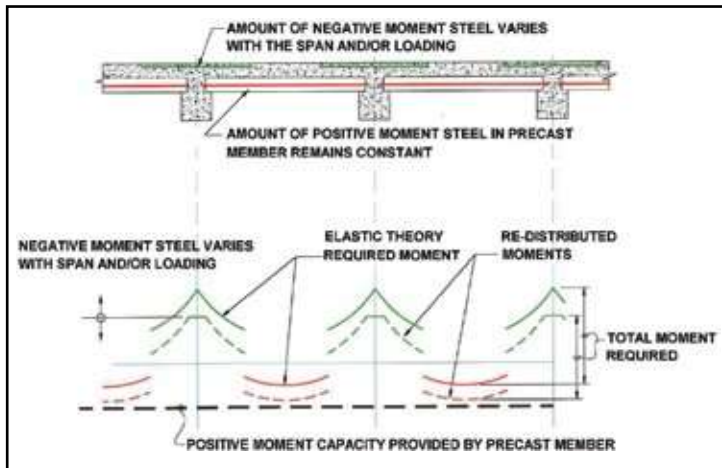

Fig. 13. Redistribution of bending moments.

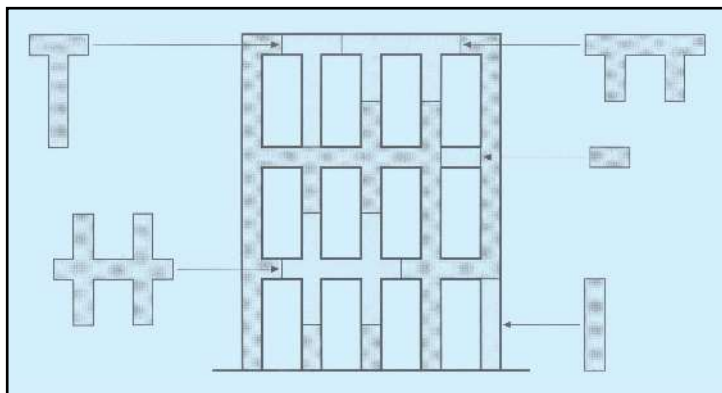
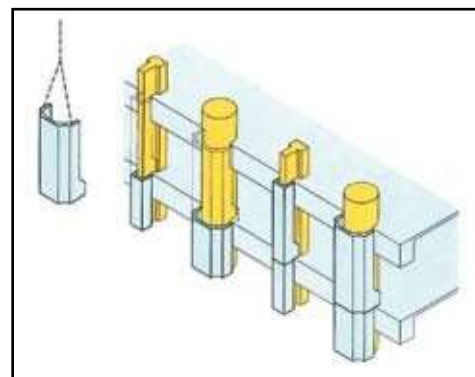
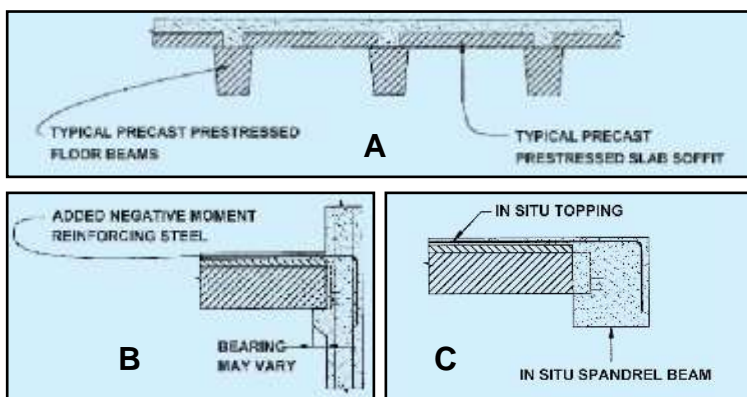

Fig. 14. Examples of alternative precast framing elements.

Precast column cladding.



Precast façade panels.



Sections A, B, and C show the precast/prestressed floor beams with the precast floor slabs and composite topping, as well as details of various connections.



Precast slabs that receive composite cast-in-place topping.



Precast beams.



The completed structure.

Fig. 15. Design schematics and methods of fabrication and erection of the Dalian Xiwang Building, Dalian, China.

MOMENT REDISTRIBUTION

For economy in production, the precast beam or slab units should be designed as much as possible for uniformity and repetition in their fabrication to accommodate deck spans or loadings that vary within a limited range. The precast element will then have a consistent area of positive moment reinforcing steel, and the remainder of the total moment requirement in the deck span can be adjusted as needed by varying the area of negative moment steel in the composite slab or topping area (see Fig. 13).

This concept basically involves the redistribution of calculated bending moments transmitted by the plastic yielding of the negative reinforcing steel. The ACI Building Code allows a moment redistribution of up to 20 percent unless further testing or more sophisticated analyses prove otherwise.

If spans and loadings result in more than a 20 percent redistribution of bending moments, the typical precast beam or slab can be redesigned to accommodate a new level of uniform positive bending moment resistance.

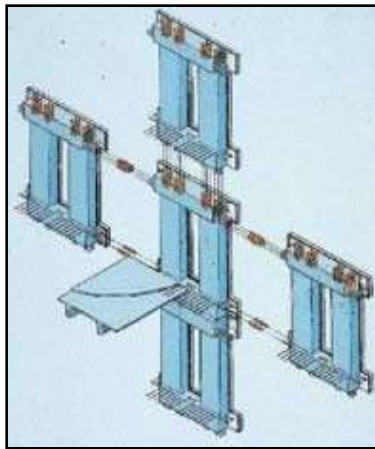

Fig. 16. The 22-story building at 100 Washington Square in Minneapolis, Minnesota. Precast panels were joined horizontally and vertically to form Vierendeel wall trusses.

STRUCTURAL PRECAST SYSTEMS

Past research and intensive testing of precast joinery with mechanical couplers and composite precast deck framing systems indicate that multistory precast building frames can be designed and constructed to resist the most severe seismic forces. The technology has progressed to the degree that virtually any convenient framing pattern can be achieved in the manufacture and assembly of precast units to form monolithically acting, seismic-resistant structures.

Fig. 14 shows how a multistory building frame can be prefabricated in parts and assembled together based on current state-of-the-art precast technology. Over the past four decades, these composite precast frame systems have been successfully used in the construction of thousands of high- and low-rise buildings in both seismic and nonseismic areas. Figs. 15 through 17 show some excellent examples of buildings using this composite precast frame concept.

This concept has proven to be most suitable for structural framing in very severe seismic areas. Experience has



Fig. 17. For the 38-story Ala Moana Hotel in Honolulu, Hawaii, precast column trees were fabricated to support precast floor slabs.

shown very convincingly that the system can produce the required strength, stiffness, ductility, and monolithic action in the overall building frame to safely resist severe horizontal and vertical ground accelerations during earthquakes. Precast concrete framing systems have proven their capacity to withstand major earthquake occurrences in Guam (United States) (Richter Scale 8.1), Manila, Philippines (Richter Scale 7.2), and Kobe, Japan (Richter Scale 6.9).

It has been shown conclusively that buildings and other structures can be built with speed and economy with precast, prestressed concrete components. Significant efficiency in labor can be achieved through factory-controlled mass-production techniques, and a high level of quality in material and workmanship can be realized as well.

These precast units can be integrated vertically and horizontally to form

CONCLUDING REMARKS

building frames that behave in a completely monolithic manner with sufficient strength, stiffness, and ductility to safely resist seismic forces. Mechanical steel couplers and in situ reinforced concrete play an integral role in providing a medium for joining together all the precast elements into a composite frame. These systems have performed successfully in both low and high rise buildings exposed to severe seismic forces over the past four decades.

REFERENCES

1. Yee, Alfred A., "Prestressed Concrete for Buildings," PCI JOURNAL, V. 21, No. 5, September-October 1976, pp. 112-157.
2. Yee, Alfred A., and Kim, Chang Nai, "One Hundred Washington Square: Structural Design and Construction," PCI JOURNAL, V. 29, No. 1, January-February 1984, pp. 24-48.
3. Yee, Alfred A., "Design Considerations for Precast Prestressed Concrete Building Structures in Seismic Areas," PCI JOURNAL, V. 36, No. 3, May-June 1991, pp. 40-55.
4. Yee, Alfred A., "Social and Environmental Benefits of Precast Concrete Technology," PCI JOURNAL, V. 46, No. 3, May-June 2001, pp. 14-19.
5. ACI Committee 318, "Building Code Requirements for Structural Concrete (ACI 318-99)," American Concrete Institute, Farmington Hills, Michigan, 1999.
6. Kumar, Phani, Nukala, V. V., and Ramirez, Julio A., "Horizontal Shear Strength of Bridge Deck Panels," CE-STR-94-10, Structural Engineering School of Civil Engineering, Purdue University, 1994.
7. "Tests on Rebar Splices in Reinforced Concrete Columns Using NMB Splice Sleeves," NPD-024, Nisso Master Builders Co., Ltd.
8. Paulson, C., and Hanson, J. M., "Fatigue Behavior of Welded and Mechanical Splices in Reinforcing Steel," National Cooperative Highway Research Program, Transportation Research Board, National Research Board, Wiss Janney Elstner Associates, Inc., Chicago and Northbrook, Illinois, December 1991.