

Antilock Braking System Recent Developments and its Control Techniques

Dharmananda Barik^{1*}, Prasant Kumar Nayak²

^{1*} Assistant Professor, Department of Mechanical Engineering, Nalanda Institute of Technology, Bhubaneswar, Odisha, India

² Assistant Professor, Department of Mechanical Engineering, Nalanda Institute of Technology, Bhubaneswar, Odisha, India

*Corresponding author e-mail: dharmananda@thenalanda.com

Abstract

The capabilities of ABS can be used while driving normally, however they have no impact on handling in emergencies. You must first comprehend the characteristics of the interaction between the tyre and the road in order to create an ABS system. The ability to maintain the tyre's slip regardless of which brake is used would increase braking effectiveness. By limiting wheel lock during braking, ABS's design aims to increase vehicle traction while preserving vehicle steerability and wheel balance. Although driving in a straight line necessitates complete traction, turning might call for a delicate balance between stability and braking. Even automobiles with conventional anti-lock brakes could lose control if this type of control was used. The use of wireless accelerometers, dynamic tyre and suspension models, and adaptive control to metrics like acceleration and lateral slide are recent innovations. Recently, automotive systems like four-wheel drive have been integrated with active suspension and four-wheel steering. Future improvements might include connectivity between vehicles and sensors made of intelligent materials.

Keywords: *Active safety system, Antilock braking system, Tractional Control, Sliding mode controller, Wheel slip controller, Cornering Brake Control.* Introduction

The majority of passenger cars are equipped with antilock brakes (ABS). It handled individual pressure on the brake pedal, preventing the brake system from locking up. It was originally designed for aircraft. Current ABS technology will change the amount of steering lock-up to shorten braking distances. Moreover, ABS can be employed to increase driver security on the racetrack. Since the beginning of time, anti-lock brakes (ABS) have been used to try and eliminate lock-ups. Both automobiles and control systems exhibit an increase in braking system efficiency.

It has electronic braking systems, which considerably increase driver and vehicle safety on slick roads and during severe braking. A traditional braking system, an electronic control unit (ECU), commonly referred to as an electronic brake modulator (EBC), and a magnetic sensor for tracking the speed of the vehicle are typically included in an ABS system. In the event that the wheel locks, the brake system pressure is reduced before the locking cylinder's speed is attained.

The ABS controller's ability to maintain a fixed longitudinal slip is made possible via electronic circuits and tyre sensors. The electronic controller is informed about the driving speed of the wheels through speed sensors. The electronic controller determines the amount of torque in accordance with the variations in wheel speeds, and in turn, regulates the solenoid valves on the master cylinder that are in opposition to the various wheels.

Road Safety System

Almost 900 articles on road safety were published annually around the turn of the 20th century. In 1990, there were only roughly 250 articles on road safety that were published; in 2016, there were twice as many books, journal articles, papers, and reports. Figure 1 shows how the study has reduced traffic fatalities. The Indian government established goals to reduce yearly mortality by 27,000 in 2010 and to 15,750 by 2020. The numbers show that as the aim was attained, there were more casualties [1–5]. A number of measures have been implemented to enhance road safety, such as the implementation of lighting and construction of new roads, or improvement of the existing infrastructure. It also influences the level of protection for the driver and passengers.

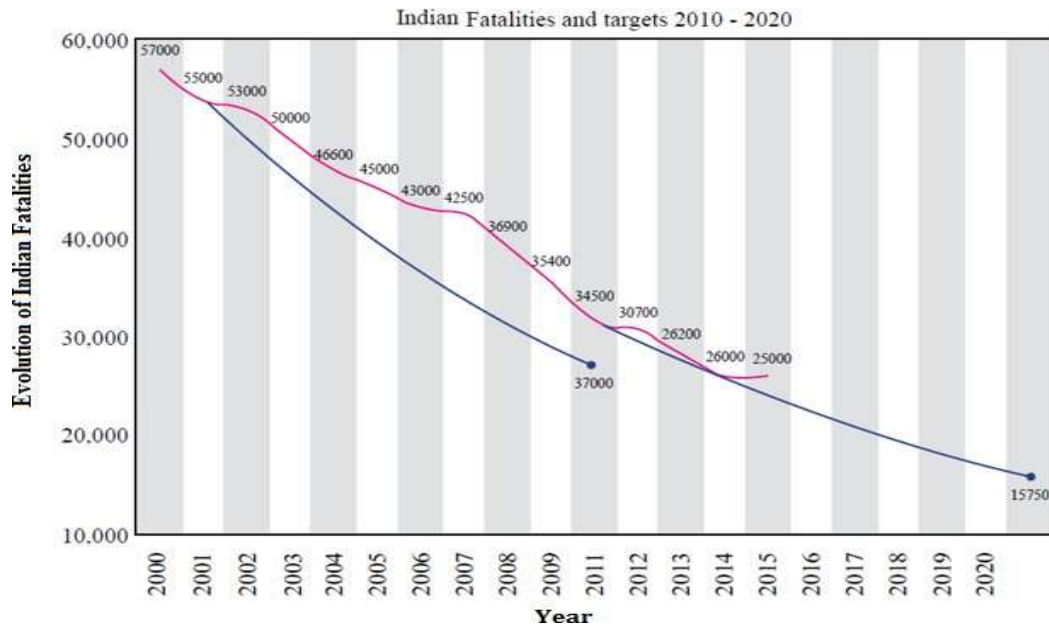

Figure.1. Yearly number of articles on road safety research from 2000 to 2020.

In general, safety systems may be said to be either constructive or reactive. The passive protection systems help to minimize damage after a collision. Active protection mechanisms seek to avert mishaps, which is why they are put in place prior to the incident.

Passive safety systems are typically include airbags, seat belts, and other parts that take on the shape of deflection in the event of an accident. passive protection is believed to be within the realm of human development capabilities [6,7] Much of the time, if your vehicle's steering does not work, your ABS is inoperative. Before he lost control, the initial aim of ABS was to ensure that the vehicle wouldn't lose its brake control. This is done by making sure that the wheel does not engage. If another mechanism is able to prevent the vehicle from skidding or losing traction, such as Anti-lock Braking System (ABS), Electronic Stability Control (ESC), or Traction Control, then it will operate (TC).

By the year 2004, vehicle manufacturers in the Netherlands were legally bound to install anti-lock brakes (ABS). In 1978, the first practical implementation of ABS was completed in an automobile. The value of this design has only increased with modern day crash prevention systems. The weight of the seat has been decreased by 85% and the algorithms have been fine-tuned as well. several studies have been done on the efficacy of ABS [8,9] A study was conducted that found that cars with ABS are more likely to be involved in traffic accidents, but are slightly more likely to be involved in other collisions when being driven off-road. The estimated gap is approximately 9 percent with respect to vehicles that do not have ABS. This appears to happen even on roads with little wear and tear. It is revealed that the incidence of

such events has increased by 34%. More rigorous research has been done and has found that ABS has lowered the risk of non-fatal vehicle collisions by around 6%.

Brief History of ABS

The first ABS dates back to 1929 and is credited to the French automobile and aircraft pioneer Gabriel Voisin. The first artificial ABS brakes were inserted on a Boeing B-47 aircraft to avoid spinouts and tire skidding later in 1945 the most significant innovations in the history of aviation safety in the year 1952 There was significant progress in the ability to apply the brakes and a significant decline in the risk of wheel-spin and burst of tires, which lowered landing distances (approximately 30%) as a lot. CAB Stainless steel brakes have been used in airplanes from that point onward.

Automatic pilots and fly-by-wire were already well established as pioneering systems in the aviation at that time, but found their way only to the top end of the line in the automotive industry. ABS is the first offered by the British Jensen Interceptor in 1972. Since electronic technology was difficult to use and the public was indifferent to its minimal reliability, it started to go out of style in the 1970s.

This was the year that marked a great change in the digital electronics industry, as the Bosch anti-type ABS was first used in Mercedes-Benz automobiles for the first time, the four-wheel ABS was fully electronic and required no intervention by the driver at all. Immediately after they launched their launch campaigns, other companies such as Audi, Lexus, and Mercedes went bankrupt. Also in the mid-1980s, Japanese car and bicycle manufacturers introduced ABS brakes, both originating from the Bosch system and their own designs. Bosch was used in this vehicle in the Corvette in 1986, and in the Allante Cadillac in 1987. Since the late 1980s and early 1990s, ABS components have been widely used on the leading model lines. In the early 2000s, four-era, almost all passenger vehicles and light commercial vehicles were fitted with four-wheel anti-anti-lock brakes.

Goals of ABS

For a modern ABS, there are three primary goals: the system architecture, control algorithm, and system design approach.

Stopping Distance By maximizing the longitudinal frictional force, the stopping distance will be minimized for the same vehicle mass m and initial velocity v_0 .

$$d_{braking} = -\frac{v_o^2}{2\alpha_x} \text{ where } \alpha_x = \frac{F_x(\mu)}{m} \quad (1)$$

Steerability available lateral force diminishes with slip In order to prevent the vehicle from turning; the ABS should be able to sustain adequate friction at a constant rate.

Stability For uneven and abrupt changes on the pavement, having the highest friction level on all four wheels is not ideal. A significantly unbalanced distribution of right and left braking powers, shown in Figure 2, leads to a roll moment and as well as to vehicle instability Thus, it is necessary for ABS to maintain an even total braking pressure no matter what pressure the rider has applied.

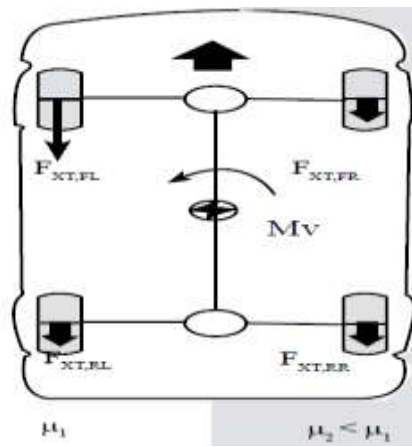

Figure.2 Buildup of yaw moment induced by large differences in friction coefficients.

ABS Components

A typical ABS comprises a series of subsystems interconnected in a control loop (Figure 3). The main components of an ABS are ECU, Hydraulic Modulator and Sensors.

Electrical Control unit (ECU) In most instances, microprocessor-based, the microprocessor performs these functions for vehicle and wheel slip estimate correction. After calculating the implemented control scheme, the ECU issues a signal to the hydraulic modulator according to the algorithm.

Hydraulic Modulator an electromechanical system that has the ability to apply brake line pressure to solenoids depending on ECU signal.

Sensors As these are coupled to the signals indicate rotational velocity of all of the wheels (inductance or piezoelectric calculation usually with a sensor on the wheel hub), as well as the pressure and acceleration of the brakes (accelerometer on the CG).

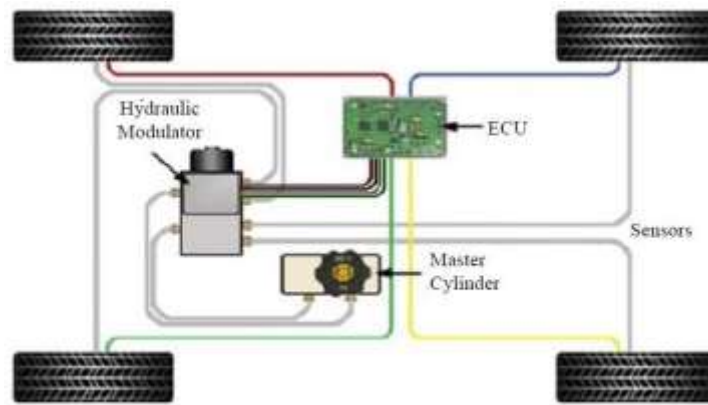

Figure.3. ABS Components diagram

System Simulation description

A proposed simulation test was done by M.W, et al., and this author, who simulated the operation in real time using the hardware (HIL). Unfortunately, but still, though, the paper describes it as having a vacuum booster integrated in the design[10,11]. One more aspect of the device in the paper that should be noted is that the use of a vacuum booster for the active brake control is omitted. the Hydraulic booster could be more capable of producing a higher boost, which could improve braking pressure and brake response. The hydraulic actuator is a combination of a master cylinder, power supply, an accumulator and a wheel brake. When the driver applies the accelerator, the booster produces an assist force that increases the pressure in the fluid.

The machine is operated by an electric servomotor, which needs a longer reaction time than the hydraulic components. Therefore, the focus of the review will be on the hydraulic system results. When the machine allows the booster and master cylinder to be actuated, power and control valves are in operation. Connecting the engine braking assembly to the master cylinder is also amplifies the input pressure from the pedal force input[13,14]. The rotating tires are drawn with DC servomotor strainers to simulate the tractive force applied by the braking circuit. The computer computes the friction, tire velocity, and vehicle speed requirements. The ECU or the machine may regulate the brake fluid pressure.

When opposed to traditional vacuum boosters, the hydraulic boosters have the following features: Using high accumulator pressure means higher brake booster ratio and faster reaction. The effectiveness of the disc brake can be actively maintained by regulating the hydraulic pressure in the pressure chamber. ideally ideal for a variable boost and a layover/adaptive system. The master cylinder and brake booster unit are mounted along the

same (x, y) axes; since it uses the same power supply unit for the master cylinder and brake booster.

Hydraulic assist assists the driver's hand to increase pedal force, as with brake input, or assists the driver with the hydraulic force by applying the same To demonstrate the qualitative and braking characteristics of the hydraulic booster, in figures 4 and 5, we display the brake booster is represented in terms of its qualitative responses. The hydraulic booster displays a greater brake boost ratio and a rapid pressure response.

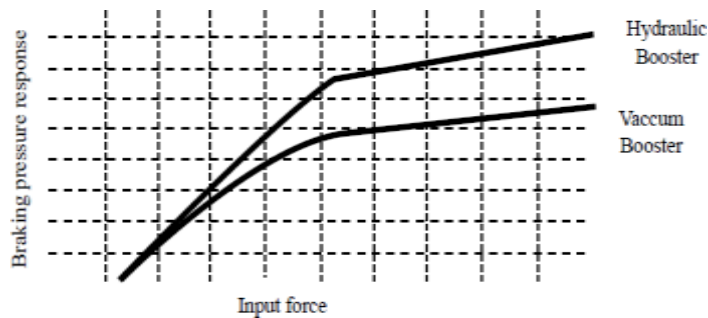

Figure.4. Brake Booster Characteristics

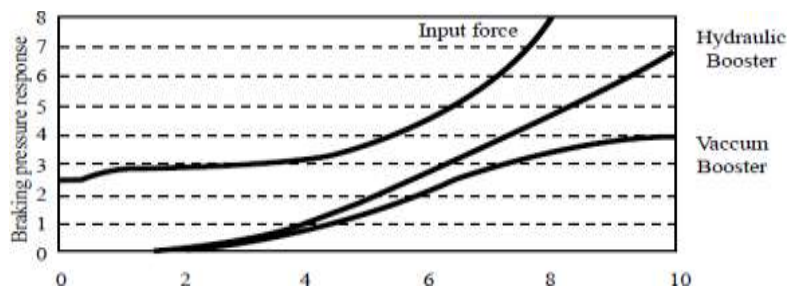

Figure.5. Braking Pressure Response

In this analysis, the flowchart was analyzed in Figure 6. The system includes: vehicle and wheel slip and traction control, which helps the system decide when a vehicle might skids or slips on the road, and a developing hydraulic braking system, which helps to control vehicle wheel slip. In an attempt to better monitor the level of the hydraulic system, the control logic for the braking is based on nonlinear operation [15,16]. Changes in road conditions were incorporated into the vehicle and tire models. Angular velocity and angular deceleration of the wheels can be detected by the wheel speed sensor as soon as the wheel lock is discovered, the pressure in one or more of the brakes is above a predefined level, one or more of the cylinders is decreased in pressure until the wheel speed matches or exceeds a preset value.

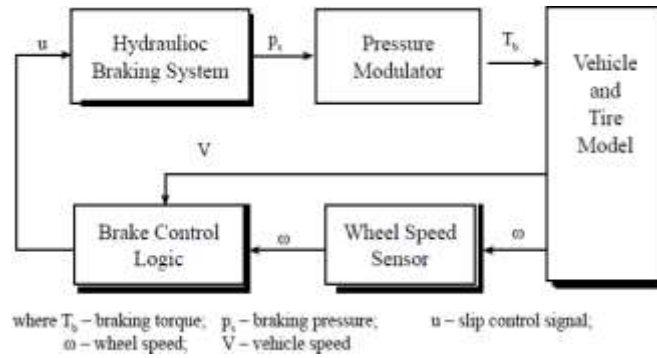

Figure.6. Basic Simulation Chart of ABS Control

Vehicle Dynamics

In Figure 7, the vehicle may be decomposed into five main components which interact as shown, each of which may be further decomposed into multiple subcomponents that interact with the other (dependent parts).

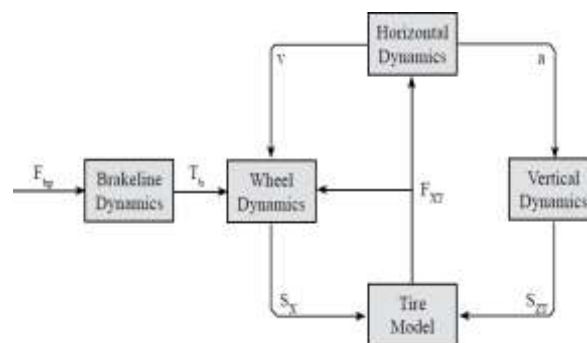

Figure.7. Vehicle dynamics Overview

Horizontal Dynamics forces applied to a CG to a body to move on an inertial plane while also rotating with respect to the axle on a tire.

Vertical Dynamics transient reaction on each wheel, as a result of longitudinal and lateral transfer as well as well as acceleration (dependent on the velocity). Vibrations and displacement measured at seven degrees of freedom are capable of detecting sudden loads and disturbances that occur on the vehicle[17,18].

Brakeline Dynamics the hydraulic brake modulator, in which there is also an ABS mechanism To return torque to the wheel it receives an external input of pedal power, it outputs the force the brake torque.

Wheel Dynamics In order to measure the resulting wheel angular acceleration, Brake Dynamics is applied, and then the force being applied on the tire's longitudinal axis is assumed to be due to a coefficient of friction.

Tire Model is empirical evidence to support the tire/pavement friction model It models the tire slip ratio and vertical load as functions of input variables, including the longitudinal slip.

Basic Control Strategies and Methods

The early ABS control laws were developed by trial and error experiments in laboratories and then improved iteratively in the field. Some theoretical and practical works have been done on the traditional ABS. Used in lists and experiments in ABS; applied in situations where a lock-up has already occurred and counteracted. However, the Flin and Fenton (1984) demonstrated frequency domain methods, and Zeller (1984) defined a classical feedback approach [19, 20]. The complicated and difficult issue of tire slip control is indeed. Several methods and iterations are made in newer versions of ABS because no matter how well you solve one problem, it gets worse in the next version. At the time of growth, it is highly prevalent in the literature to use four methods: (also referred to as "classifications") of control: Proportional integral derivative Control methods that have the greatest significance are reviewed in the following subsections.

Threshold Control

In the early stages of the ABS control, threshold control was used extensively. The generic threshold algorithm typically involves changing the parameters such as wheel acceleration and/slip, or setting the upper and lower limits for strain. for fuel injection that used to actuate a typical controls earlier from Bosch's two-type controls is represented by a curve with three

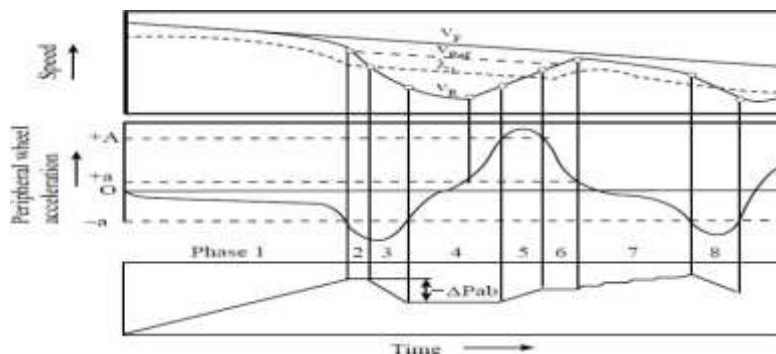

Figure.8. ABS algorithm

key points (a, -a, and A), and also a pressure-manipulation factor (λ) which

accomplishes the same. Filtering cycles using different control variable thresholds may also have major impacts on the efficiency of other features of the model, as shown by Rangelov. Since pressure is changed in one direction and in binary states (see Figure 8), wheel oscillation over time is less under the continuous control methods. Despite this, however basic, threshold regulation has been used for control purposes in the literature for many years. In the last decade, a four-wheeled vehicle dynamics model with longitudinal, lateral, vertical, and braking parameters has been used to accurately predict the ABS behavior under different driving conditions. The early ABS control laws were developed by trial and error experiments in laboratories and then improved iteratively in the field. Some theoretical and practical works have been done on the traditional ABS [21,22]. Of these and various criteria presented in ABS, only Guntur (1972) and Ouerk (1973) defined lockup, and the necessity of applying the brakes prior to preventing it. The describing mechanism by Flin and Fenton (1981) and a classical feedback control by Zeller (1984) were used to characterize ABS in terms of its frequency of occurrence. At least some other diverse aspects of ABS control are related to the growth. Only the gentler processing of individual thoughts and feelings are noted in this section.

PID Control Method

In industry, the traditional PID is by far is the most commonly used type of PID control. It is simple to comprehend, simple to style, and easy to deploy. Long-Widely used in various applications, from which ABS is no exception The PID calculation, as a traditional control method, can be used to apply processes as a component, is more economical, easier to implement, and better-time, and for that reason, is part of process control. One of the methods of accomplishing the on-line self-tuning co-efficient (K_i), is by means of the neural tuning (K_{PP}), simple co-tunation (K_i) and differential tuning (K_d). The progression of the effect of PID control is entirely due to the control. The slip ratio of the wheels is the control target of ABS controller, while the real slip rate and the desired slip rate are the inputs for the ABS pressure actuator. No linear proportional-integral-derivative (PID) regulation has been implemented on a class of ABS issues. In order to make ABS more effective, the conventional PID has been improved. Fuzzy and basic PID control (called "Automatic Optimization Algorithm") were used in the design of the PID controller. This PID was more accurate and stable when calculated in terms of PID tuning.

Other Control Methods

An adaptive-sliding algorithm for a vehicle control included the least-squares estimate, as well as the sliding control algorithm, and was defined by Unknown friction was tried in an existing road-system architecture braking system.

It integrates brake pressure, speed rate, and vehicle deceleration comparison in a fuzzy-logic recognition scheme. Using a learning mechanism to regulate slip to a defined goal slip, the proposed Fuzzy-ABS controller had. using fuzzy-based build, design, set up and adjust a track system for a four-wheel-drive vehicle

Additionally, regulation over the ABS mechanism also utilizes V-structure techniques. Sliding control law proposed a linear feedback controller in their ABS scheme.

The “sliding mode” law of non-reciprocal controls was stated by someone using non-reciprocal controls. Longitudinal accelerometers and wheel sensors can be used to compute the optimal slip rate using the data.

Conclusion

The capabilities of ABS can be used while driving normally, however they have no impact on handling in emergencies. You must first comprehend the characteristics of the interaction between the tyre and the road before you can develop an ABS system. The ability to maintain the tire's slip regardless of which brake is used would increase braking effectiveness. By preventing wheel lock during braking, ABS's design aims to increase vehicle traction while maintaining vehicle steerability and wheel balance. Although driving in a straight line necessitates complete traction, turning might call for a delicate balance between stability and braking. Even automobiles with conventional anti-lock brakes could lose control if this type of control was used.

References

- Hagenzieker, M.P.; Commandeur, J.J.; and Bijleveld, F.D. (2014). The history of road safety research: A quantitative approach. *Transportation Research Part F: Traffic Psychology and Behavior*, 25(2), 150-162.
- Hulten, J. (2006). Active safety introduction. *Volvo Car Corporation Presentation at CTH*.
- Khan, Y. (2014). Modeling, experimentation and simulation of a brake apply system. *ASME Journal of Dynamic Systems, Measurement, and Control*, 116(1), 111-122.

Raza, H. (2017). Modeling and control design for computer-controlled brake system. *IEEE Transactions on Control System technology*, 5(3), 279-296.

Gowda, D.V.; Kishore, D.V.; Shivashankar.; Ramachandra, A.C.; and Pandurangappa, C. (2016). Optimization of motorcycle pitch with nonlinear control. *Proceedings of the 1st IEEE International Conference on Recent Trends in Electronics, Information and Communication Technology (RTEICT)*. Bangalore, India, 1656-1660.

Gerdes, J.C.; and Herdrick, J.K. (2015). Brake system modeling for simulation and control. *ASME Journal of Dynamic Systems, Measurement, and Control*, 121(3), 496-503.

Johnson, C.T.; and Lorenz, R.D. (2016). Experimental identification of friction and its compensation in precise, position controlled mechanisms. *IEEE Transactions on Industry Applications*, 28(6), 1392-1398.

Pandurangappa, C.; Gowda, D.V.; Kishore, D.V.; and Ramachandra, A.C. (2016). Two wheel vehicle model development for driving simulator application. *GIT Journal of Engineering and Technology*, 9(1), 47-51.

Garett, Sohl, A.; James,; and Bobrow, E. (2016). Experiments and simulations on the nonlinear control of a hydraulic servo system. *IEEE Transactions on Control Systems Technology*, 7(2), 238-247.

Srinivasa, R.; Guntur, R.R.; and Wong, J.Y. (2016). Evaluation of the anti-lock brake systems using laboratory simulation techniques. *Vehicle Design*, 1(5), 467-485.

Gowda, D.V.; and Sadashiva Chakrasali, V. (2014). Comparative analysis of passive and semi-active suspension system for quarter car model using PID controller. *Proceedings of the International Conference on Recent Trends in Signal Processing, Image Processing and VLSI (ICrSIV)*. Karnataka, India, 510-517.

Ackermann, J.; and Sienel, W. (2015). Robust yaw damping of cars with front and rear wheel steering. *IEEE Transactions on Control Systems Technology*, 1(1), 15-20.

Davison, E.J.; and Ferguson, I.J. (2016). The design of controllers for multivariable robust servomechanism problem using parameter optimization methods. *IEEE Transactions on Automatic Control*, 26(1), 93-110.

Gowda, D.V.; and Ramachandra, A.C. (2017). Slip ratio control of anti-lock braking system with bang-bang controller. *International Journal of Computer Techniques*, 4(1), 97-104.

Usal, C.; and Kachroo, P. (2017). Sliding mode measurement feedback control for antilock braking systems. *IEEE Transaction Control Systems Technology*. 7(2), 271-281.